

**THE KEVIN HAGGERTY**  
**INNER CIRCLE**  
**TRAINING PROGRAM**

June 14, 2005

# Trap Doors

## Chart Guidelines

- Ninety-five percent of the Trap Door entries will be from a three- to six-bar pattern. The exception is when it is an extreme discount/premium opening that gets to at least the 1.0 volatility band on the actual opening.
- Most patterns will have two bars, excluding the opening bar, that will have a lower high and lower low than the preceding bar (reverse for sells).
- The signal bar, which indicates a possible change in direction, should close above the midpoint and is best if in the top part of the range on increased volume. An exception would be the inside-bar pattern and another would be the narrowing-range pattern.

# Trap Doors

1. Opening bar below the previous close.
2. First lower high and low following the opening bar.
3. Signal bar, which is also the second bar with a lower high and low. It qualifies as the signal bar because it opened and traded below the 2 bar, yet closed in the top of its range. This sets up entry above the high. Indications of buying pressure. Look for a volume increase.
4. Entry bar: Which should be a trade-through entry, not a gap above the high of the signal bar (3). If it's only a couple of ticks above, you can take the trade if the dynamics are compelling.

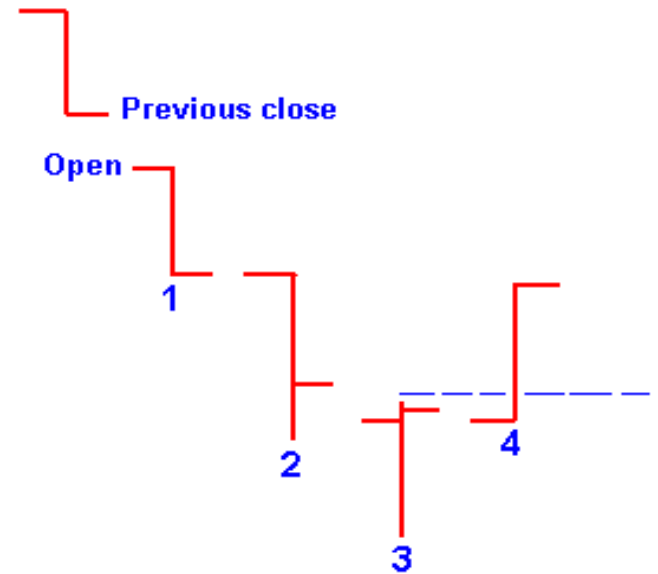

Initial stop is below the signal-bar low, or if it's a wide-range bar, then you might place it below the midpoint of the bar's range. If that is beyond your normal trade risk, then use a money stop.

# Trap Doors

B.

1. Opening bar.
2. Lower high and low.
3. Signal bar which opened below the 2 bar's low, yet reversed and closed in the top of the range above the open and above the previous close. This is a sign of buying pressure and should be in conjunction with a volume increase.
4. Entry bar.

Initial stop is the same as in (A).

**Key Point**: In any reversal buy pattern, you look for declining volume on the selloff, then an increase in volume on the change in direction (reverse for sells). Sometimes in Trap Doors, the volume increases on the entry bar, but most often you see the increase on the signal bar.

B.

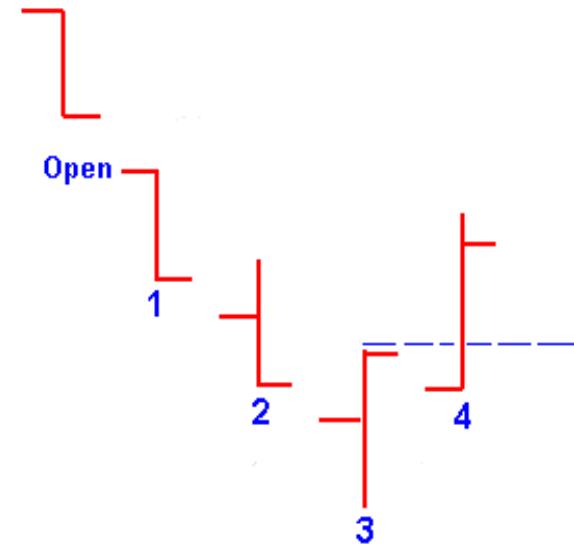

# Trap Doors

## C. Kings & Queens

1. Opening bar.
2. First lower high and low with the open near the top of the range and close at the bottom of the range.
3. Opens in the bottom of the range and closes in the top of the range, indicating buying pressure.
4. Entry bar.

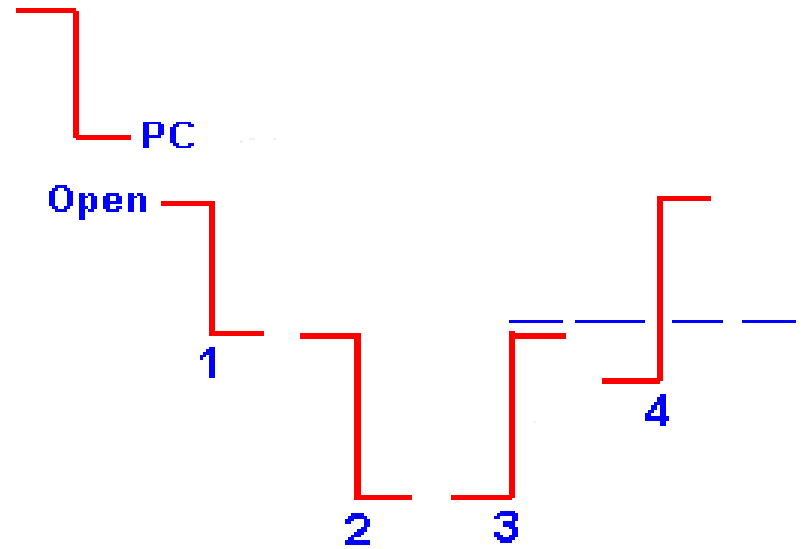

Initial stop is placed below the low of bar 3 or other options outlined in example (A).

It is called Kings & Queens when you have two bars of almost equal range with one opening in the top of the range and the next bar opening in the bottom of the range, but reversing to close in the top of the range, indicating buying pressure. You don't see it as often as (A) and (B), but it is an excellent pattern.

# Trap Doors

## D. Narrowing Range

This is a powerful pattern where each bar has a smaller range than the preceding bar, and usually the signal bar has increasing volume and closes above the midpoint or at the top of its range. If it is a very narrow bar, the close is not important, and you take entry on the next bar if it is above the signal bar's high.

1. Opening bar (wide range).
2. First lower high and low with a range less than bar 1.
3. Narrow-range bar less than bars 1 and 2. It opens below the 2 bar low and closes at the top of its range, above the open and above the previous close.
4. Entry bar.

Initial stop: Same options as (A).

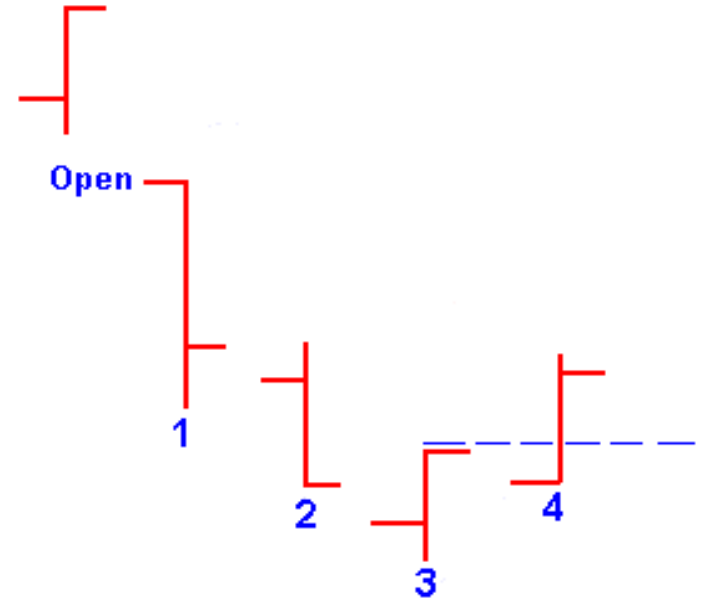

# Trap Doors

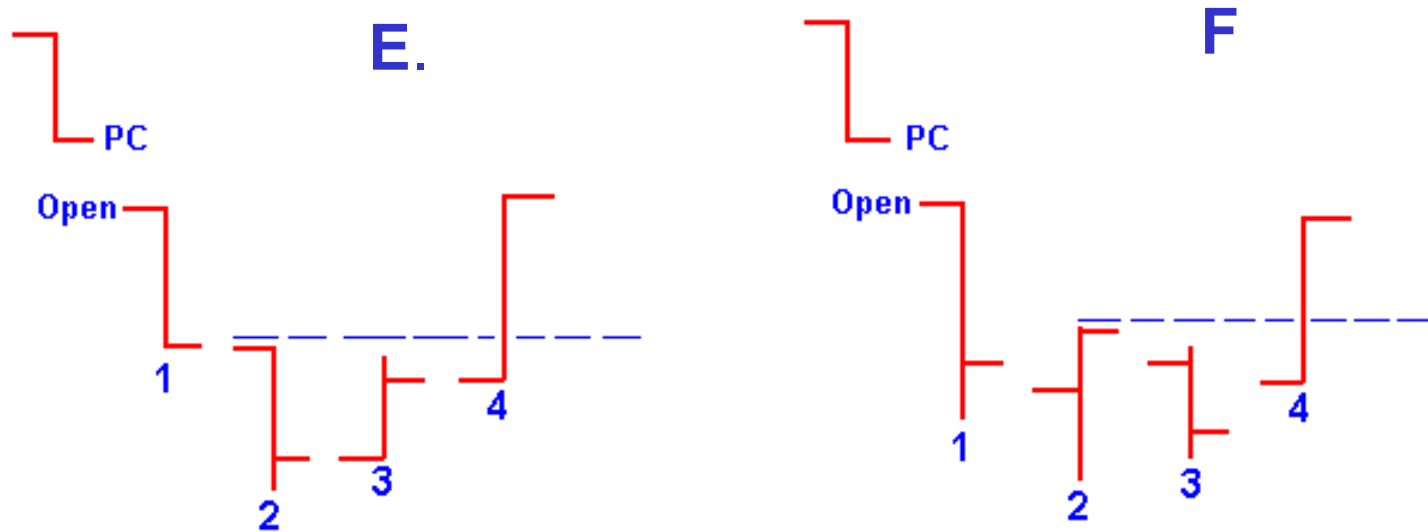

## E.

1. Opening bar.
2. First lower high and low with the close in the bottom of the range.
3. Inside bar with the close above the midpoint.
4. Entry bar with entry above the high of bar 2. If bar 3 (inside bar) closes in the top of the range on a definite increase in volume and the market dynamics are strong, then you might take entry above the high of the inside bar.

# Trap Doors

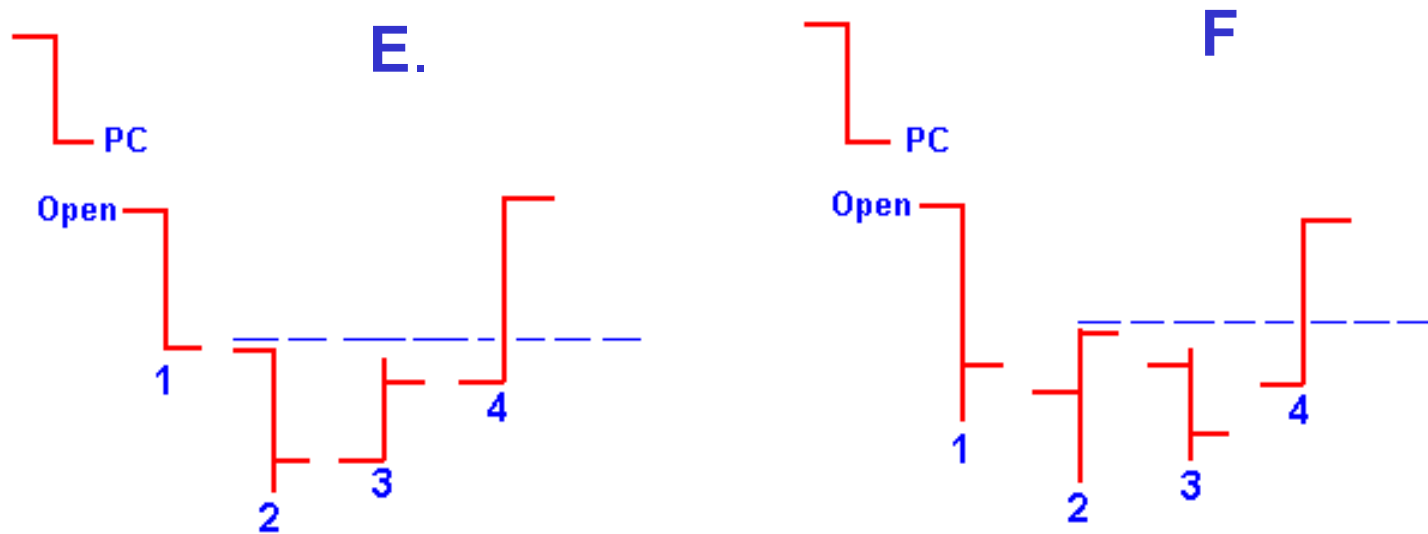

**E.**

**Key Point:** Because bar 2 is the low bar and closed in the bottom of its range, then the inside bar (3) might be just a pause bar before a break below the 2 bar's low and further downtrend. This is not my favorite inside-bar pattern, as pattern F is much stronger because the low bar is also a signal bar that indicates buying pressure with the top-of-the-range close.

# Trap Doors

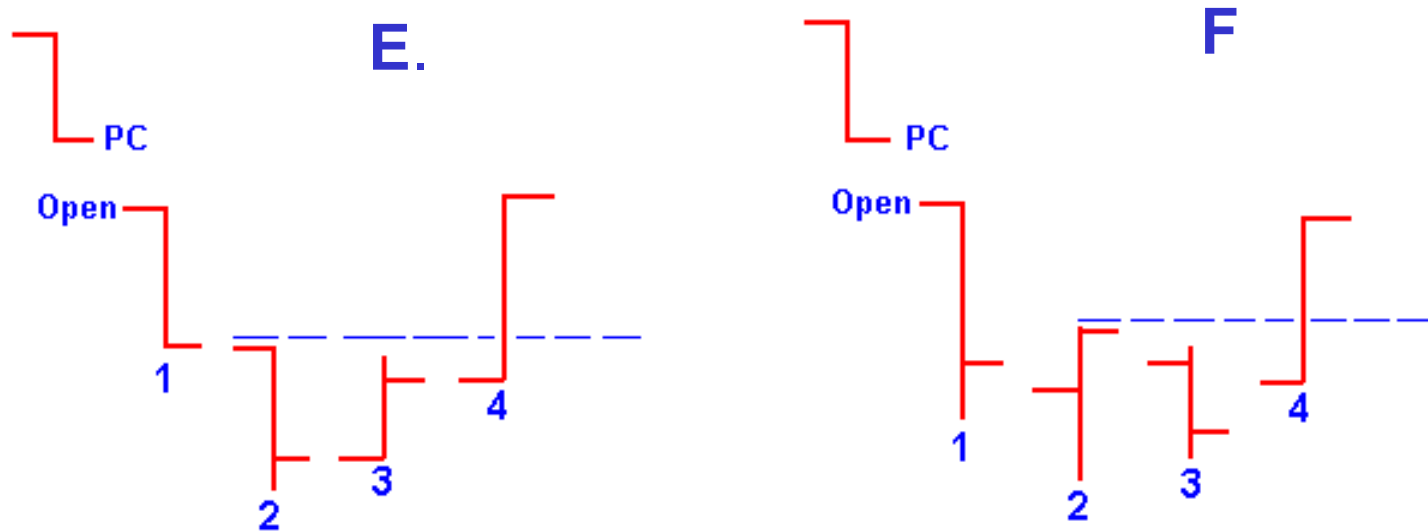

**F.**

This inside-bar pattern is stronger because of bar 2's close in the top of the range and most likely is an inside-bar pause. Entry is above the high of bar 2 and has a better trading potential than chart E.

Initial stops for both E and F are placed below the low of the low bar, or else use the other options as outlined in pattern (A). You will choose the options if the low bar is a wide-range bar

# Trap Doors

G.

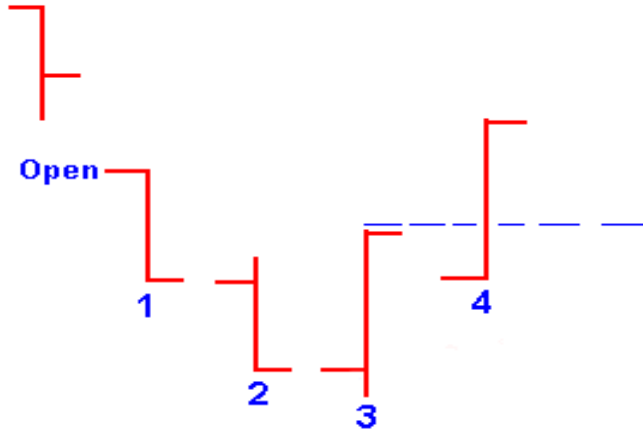

H.

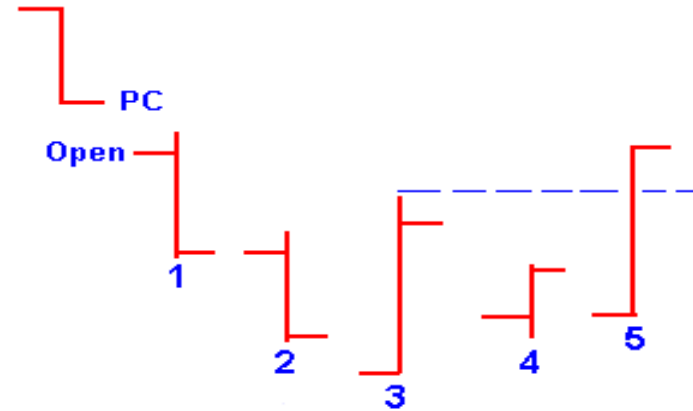

G.

1. Opening bar.
2. First bar lower high and low.
3. Outside bar with the close in the top of the range and above the previous bar's high after opening and trading below that bar's low.
4. Entry bar.

Initial stop: Place your initial stop below the low of bar 3, but most of the time, because it is a wide-range bar, you will place the stop below the midpoint of the outside bar (3) or use a money stop.

# Trap Doors

G.

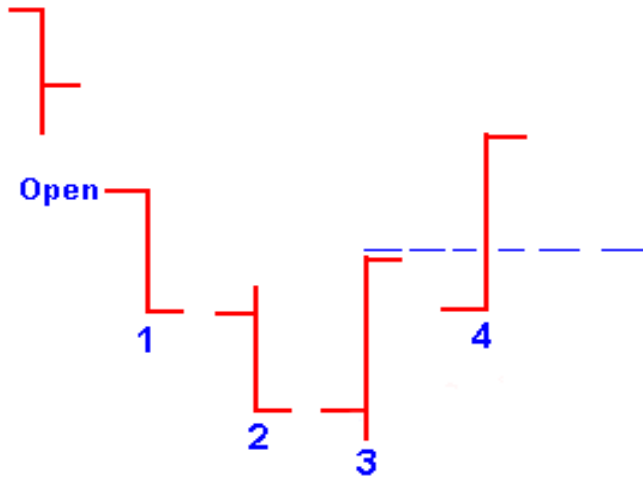

H.

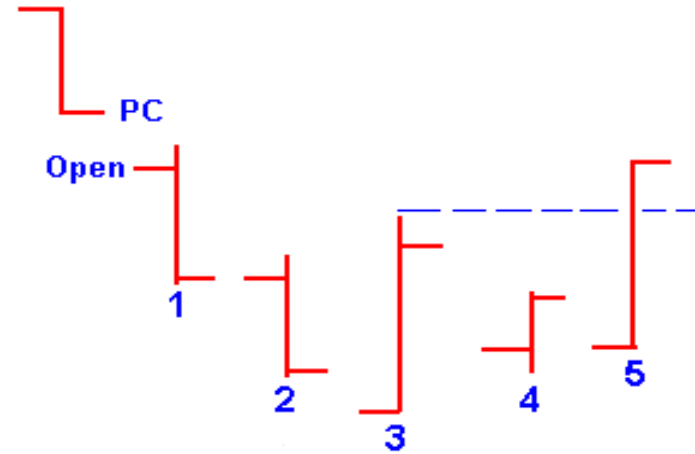

H.

This is essentially the same, except you have another inside bar (4) following the outside bar (3). Entry on this pattern can be above the high of the inside bar (4) if the dynamics remain strong. Stop placement is handled the same way as (G).

# Trap Doors

## Dynamite Triangle

I. This is an explosive six-bar pattern that can really take off, especially in a stock that has a good daily chart setup.

1. Opening bar.
2. First lower high and low.
3. Wide-range bar that opens below the previous bar's low (2), then reverses to close in the top of the range and above the previous close (not mandatory). This is your first signal bar.
4. Inside bar which delays possible entry above the signal bar's high.
5. A second inside bar which forms the Dynamite Triangle and a close in the top of the range. At this point you have a choice of entry above the high of the second inside bar or above the signal-bar high (3). If the dynamics are strong, you can take entry above the inside bar (5).

Initial stop is below the bar 5 low if not too tight, or else below the signal bar low (3).

I.

Dynamite Triangle

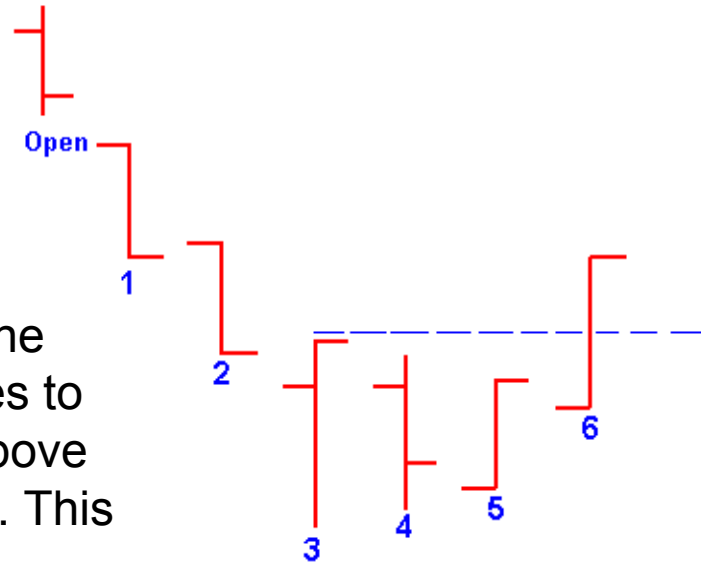

# Trap Doors

## J. Three-bar pattern

This is an example where there is a wide-range bar down on the opening, followed by a very narrow-range bar with a close in the top of the range.

**Key Point:** Narrow-range bars with a significant increase in volume usually precede a change in direction/trend.

1. Wide-range bar on opening.
2. Narrow-range bar on increased volume with a close in the top of the range.
3. Entry bar.

Initial stop is placed below the bar 2 low, unless it is too tight because of the narrow range, so you would give it some room with a money stop.

J.

Three-Bar Pattern

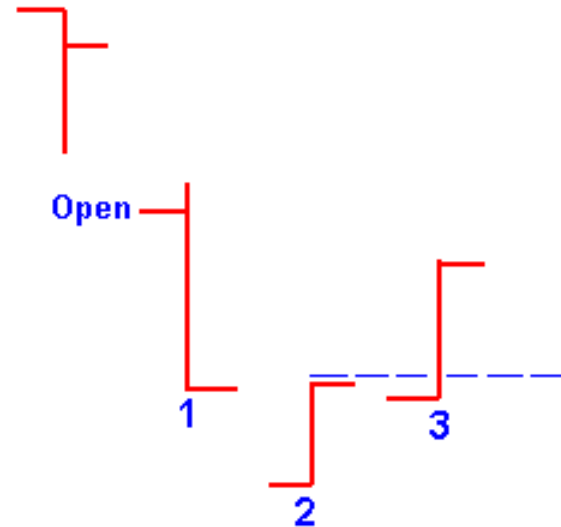

# Trap Doors

## K. Mini 1,2,3

1. Opening bar.
2. First lower high and low.
3. Second lower high and low with a close in the bottom of the range, which is not a signal bar (must close above the mid-point, unless it is a very narrow-range bar).
4. Higher high and low with the close above the bar 3 high. This is a change-in-direction bar, but we didn't take it because the previous bar closed in the bottom of the range. The bar 4 close establishes bar 3 as swing point 1. (A swing point has a higher low on each side of it. Reverse for sells.)
5. Opens and closes in the top 10% of its range on a retracement to the bar 3 low. This still indicates buying pressure.

K.

Mini 1,2,3

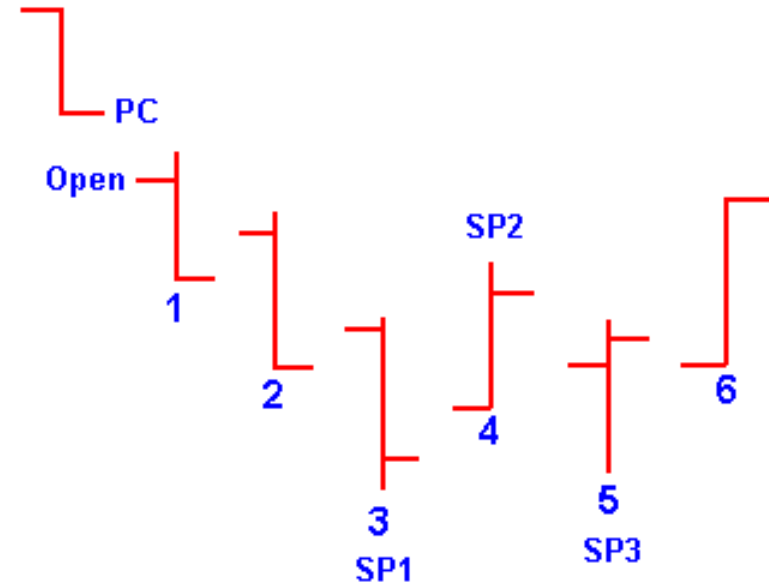

# Trap Doors

K.

Mini 1,2,3

**Key Point:** Bar 5 establishes bar 4 as swing point 2 because of the lower high and low. As you can see, swing point 2 has a lower high on each side of it. You set your entry just above the high of bar 5, which is now your signal bar because of the close in the top of the range and a higher low than bar 3.

**Entry bar** is above the signal bar high. This establishes bar 5 as swing point 3 and a confirmed higher low, which indicates buying pressure.

**Initial stop** is placed below the low of bar 5 (swing point 3).

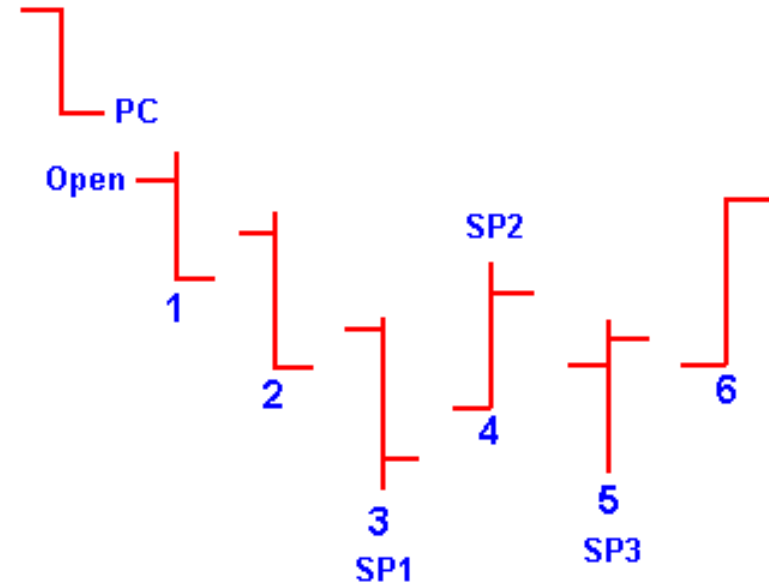

# Trap Doors

## Sell Patterns

The Trap Door sell patterns are simply the reverse image of their buy counterparts. In all of the cases, the buy rules are reversed, the same as the patterns themselves. The entry point in the diagrams is the blue dotted line.

# Trap Doors

A.

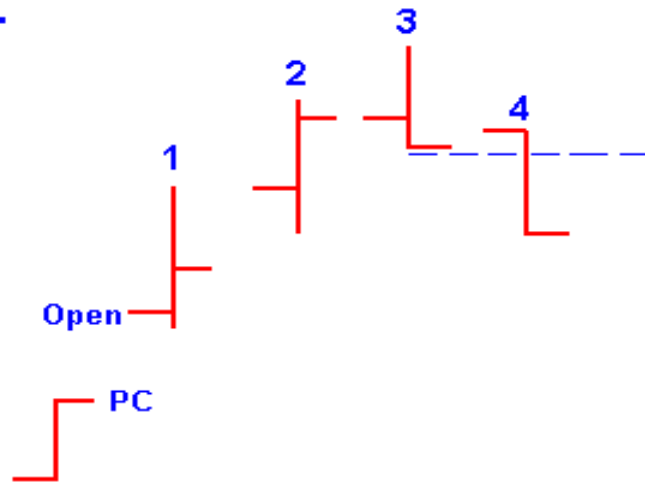

B.

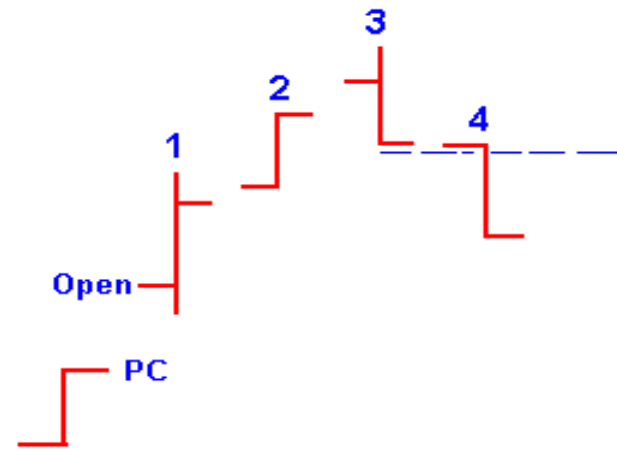

C.

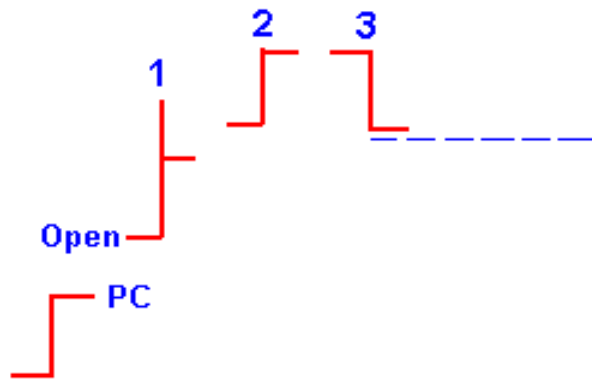

D.

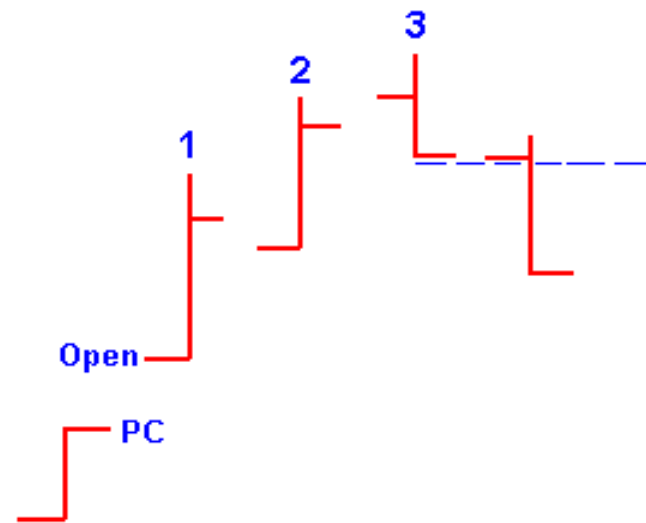

# Trap Doors

**E.**

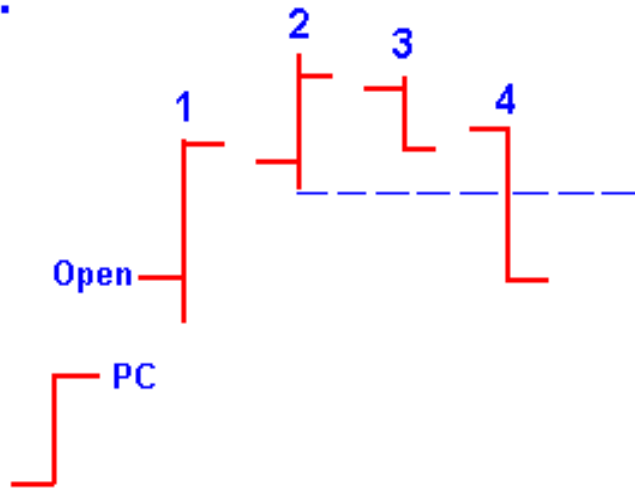

**F.**

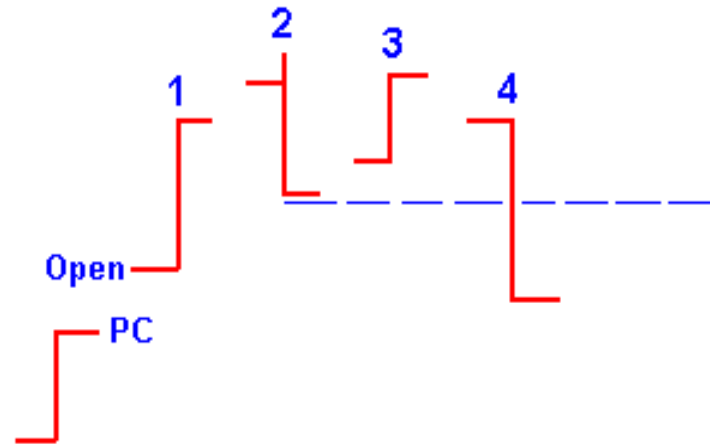

**G.**

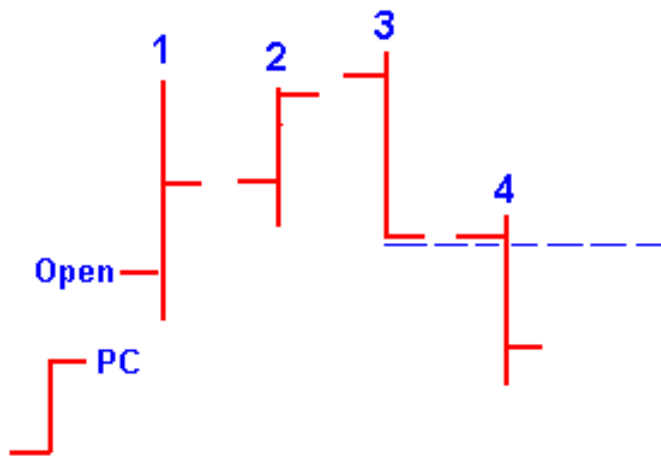

**H.**

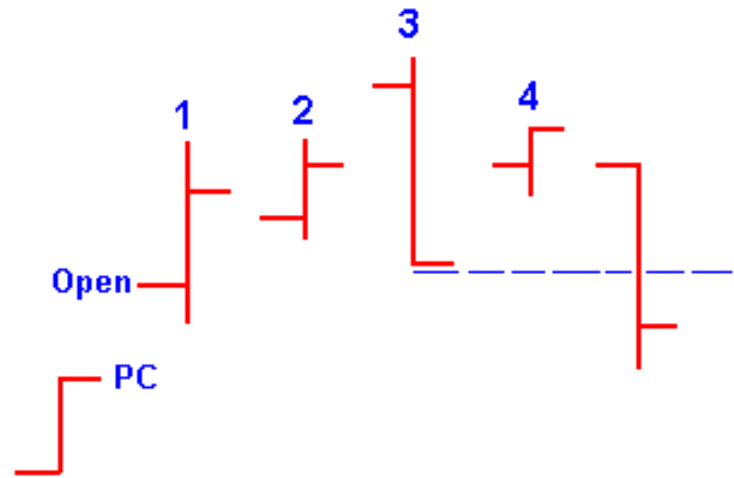

# Trap Doors

I.

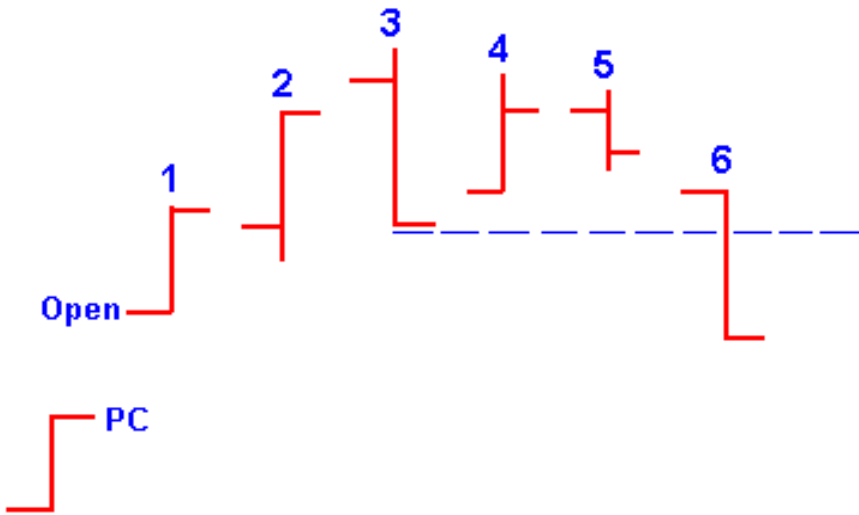

J.

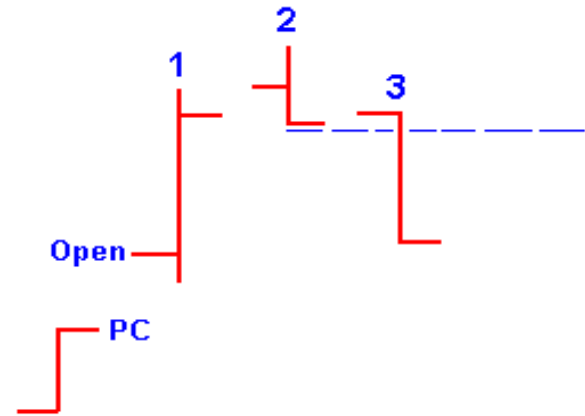

# Trap Doors

K.

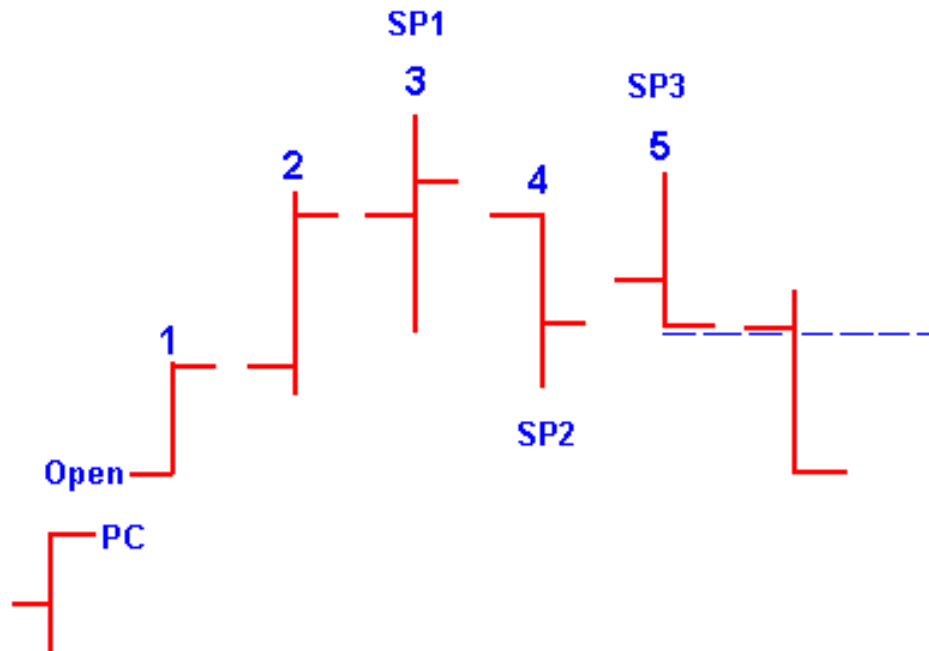

NASDAQ 100 TR SERIES I-(OTC) 37.79 -0.32 -0.84%

Exp. Mov. Avg. (8) Last=37.81  
Exp. Mov. Avg. (20) Last=37.89  
Exp. Mov. Avg. (60) Last=38.06  
Exp. Mov. Avg. (240) Last=38.18

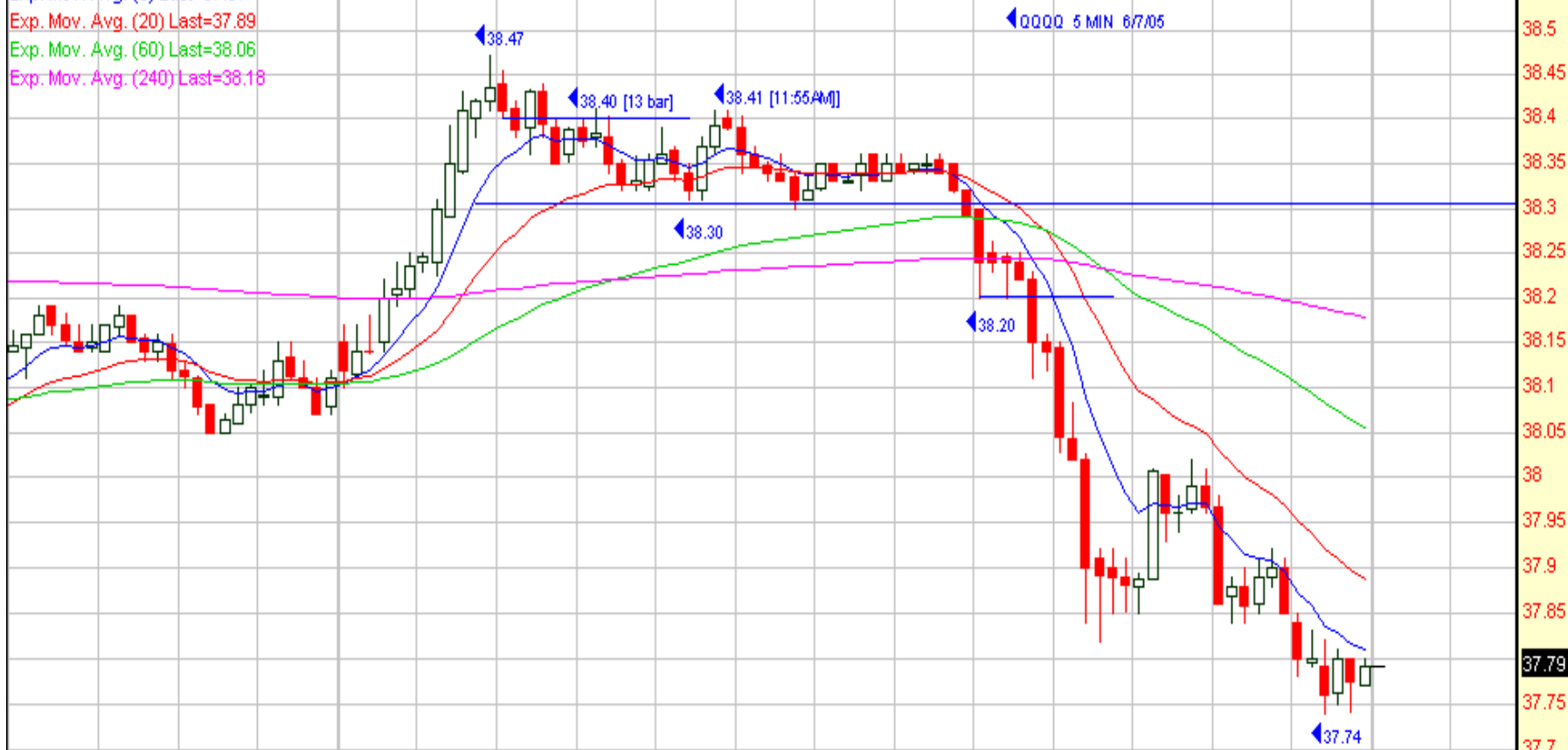

© 1998-2004 Prophet Financial Systems, Inc. | Terms of use apply.

RSI, Wilder (5)

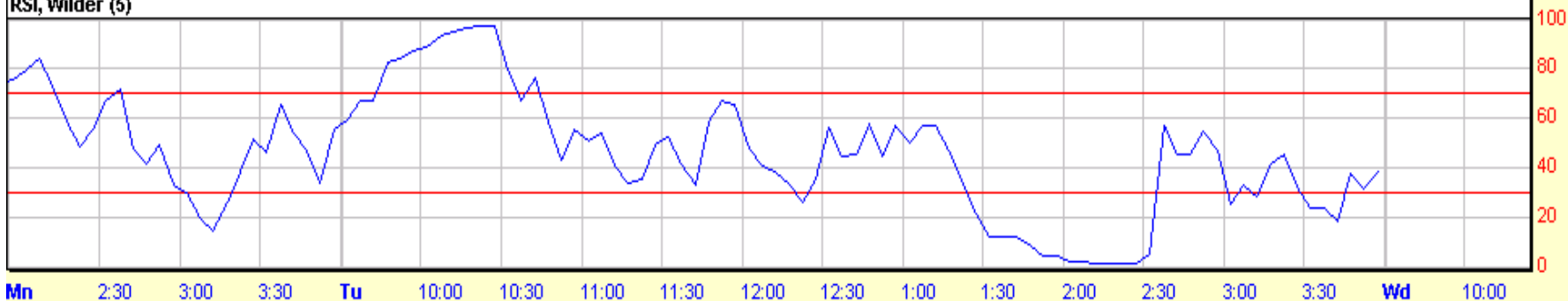

SEMICONDUCTOR HLDRS TR 34.23 -0.45 -1.30%

Exp. Mov. Avg. (8) Last=34.28  
Exp. Mov. Avg. (20) Last=34.43  
Exp. Mov. Avg. (60) Last=34.65  
Exp. Mov. Avg. (240) Last=34.73



© 1998-2004 Prophet Financial Systems, Inc. | Terms of use apply.

RSI, Wilder (5)



LOWE'S COMPANIES INC 59.00 1.07 1.85%

Exp. Mov. Avg. (8) Last=58.97  
Exp. Mov. Avg. (20) Last=59.05  
Exp. Mov. Avg. (60) Last=59.07  
Exp. Mov. Avg. (240) Last=58.29



© 1998-2004 Prophet Financial Systems, Inc. | Terms of use apply.

Volume (Thousands)

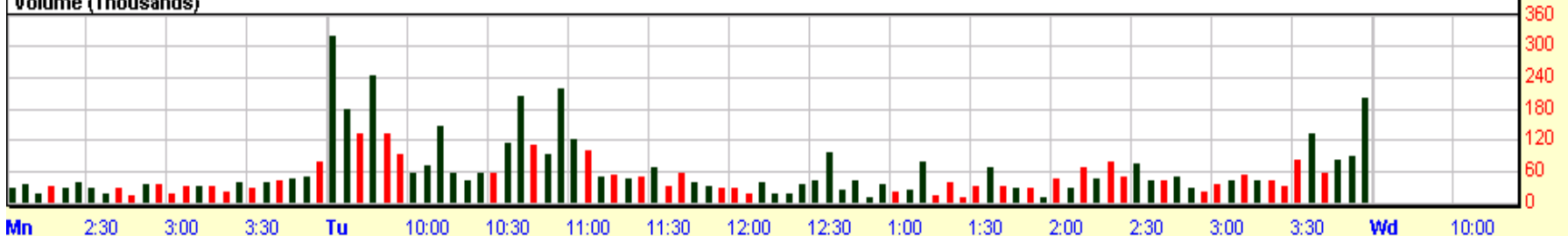

RSI, Wilder (5)



Lowes Companies 58.56 0.26 0.45%

Exp. Mov. Avg. (5) Last=56.73  
Exp. Mov. Avg. (15) Last=55.92  
Exp. Mov. Avg. (40) Last=55.56



© 1998-2004 Prophet Financial Systems, Inc. | Terms of use apply.

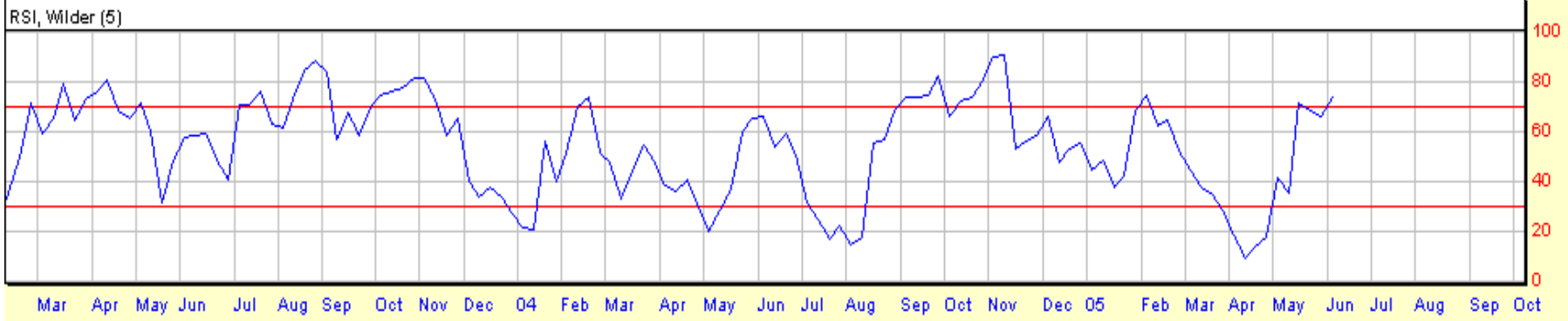

Lowes Companies 58.54 0.24 0.41%

Exp. Mov. Avg. (10) Last=58.15  
Exp. Mov. Avg. (20) Last=57.35  
Exp. Mov. Avg. (50) Last=56.30  
Exp. Mov. Avg. (200) Last=55.64



© 1998-2004 Prophet Financial Systems, Inc. | Terms of use apply.

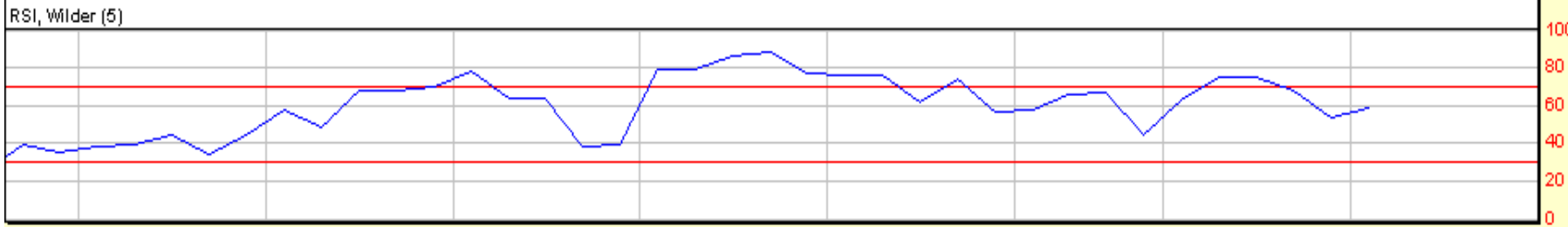
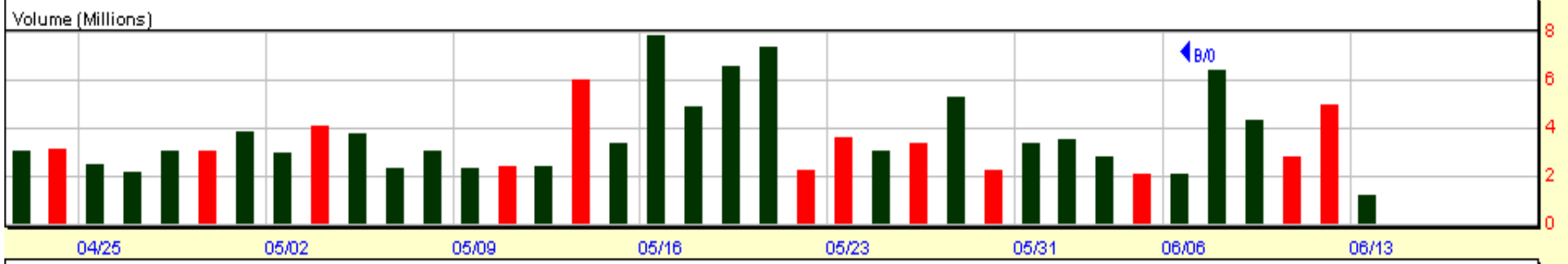

TRANSOCEAN INC 50.84 0.71 1.42%

Exp. Mov. Avg. (8) Last=50.71  
Exp. Mov. Avg. (20) Last=50.70  
Exp. Mov. Avg. (50) Last=50.86  
Exp. Mov. Avg. (240) Last=51.06



© 1998-2004 Prophet Financial Systems, Inc. | Terms of use apply.

Volume (Thousands)

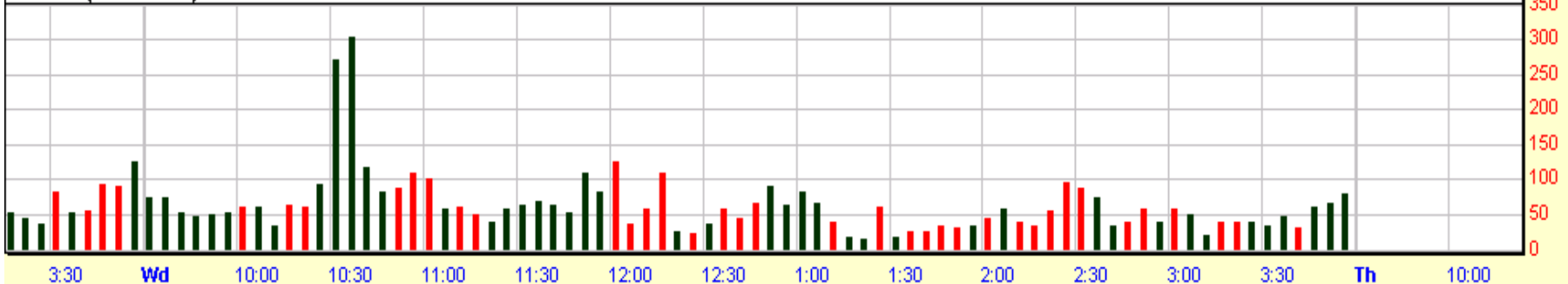

OIL SERVICE HOLDERS TR 95.35 0.80 0.85%

Exp. Mov. Avg. (8) Last=95.06  
Exp. Mov. Avg. (20) Last=95.00  
Exp. Mov. Avg. (60) Last=95.27  
Exp. Mov. Avg. (240) Last=95.35

DIH 5 MIN 6/8/05

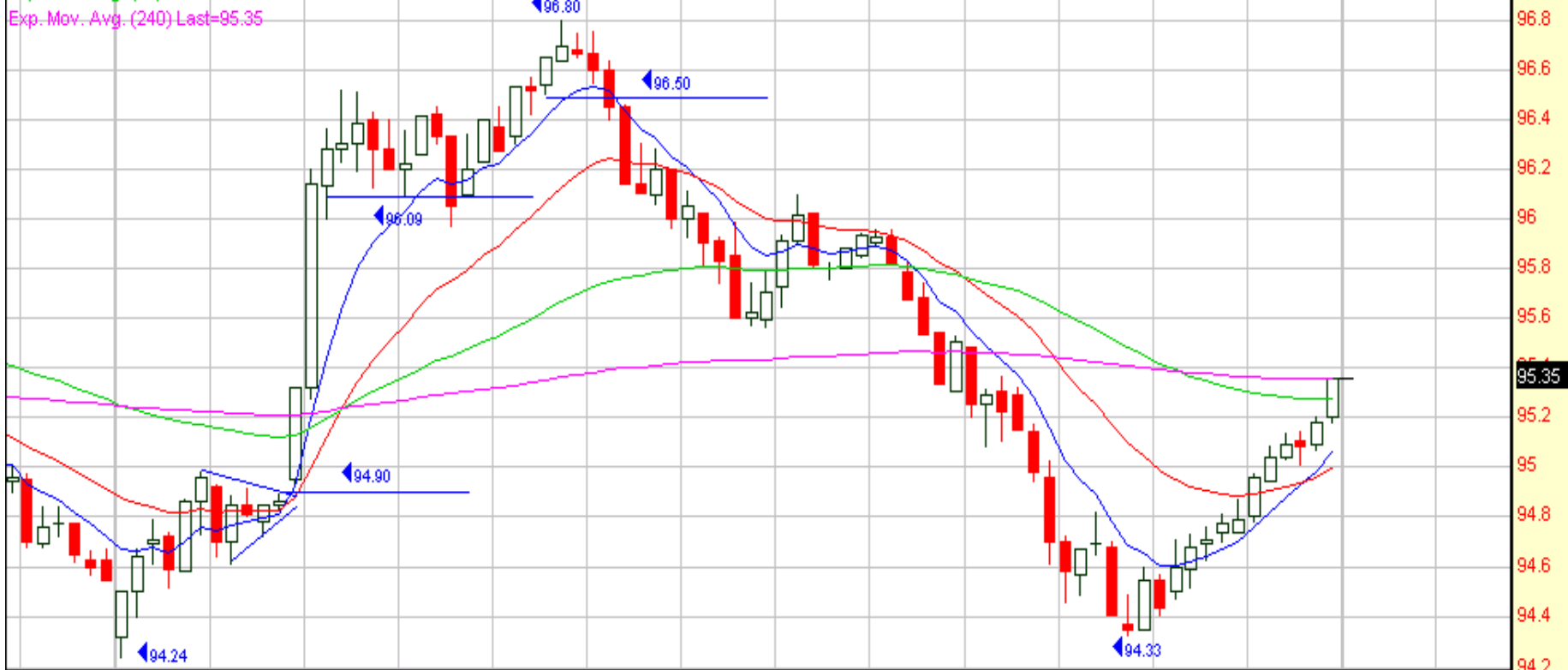

© 1998-2004 Prophet Financial Systems, Inc. | Terms of use apply.

Volume (Thousands)

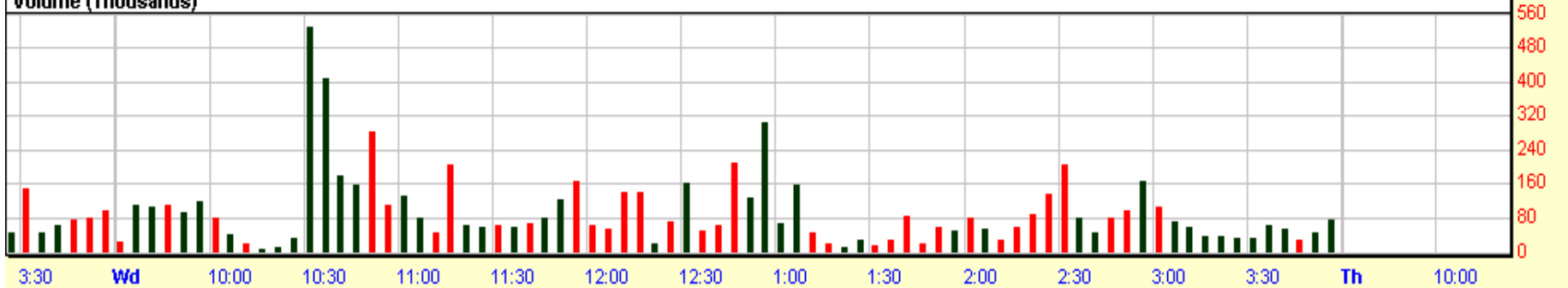

STANDARD & POORS DEP REC 119.91 -0.22 -0.18%

Exp. Mov. Avg. (8) Last=119.90  
Exp. Mov. Avg. (20) Last=119.90  
Exp. Mov. Avg. (50) Last=120.08  
Exp. Mov. Avg. (240) Last=120.30

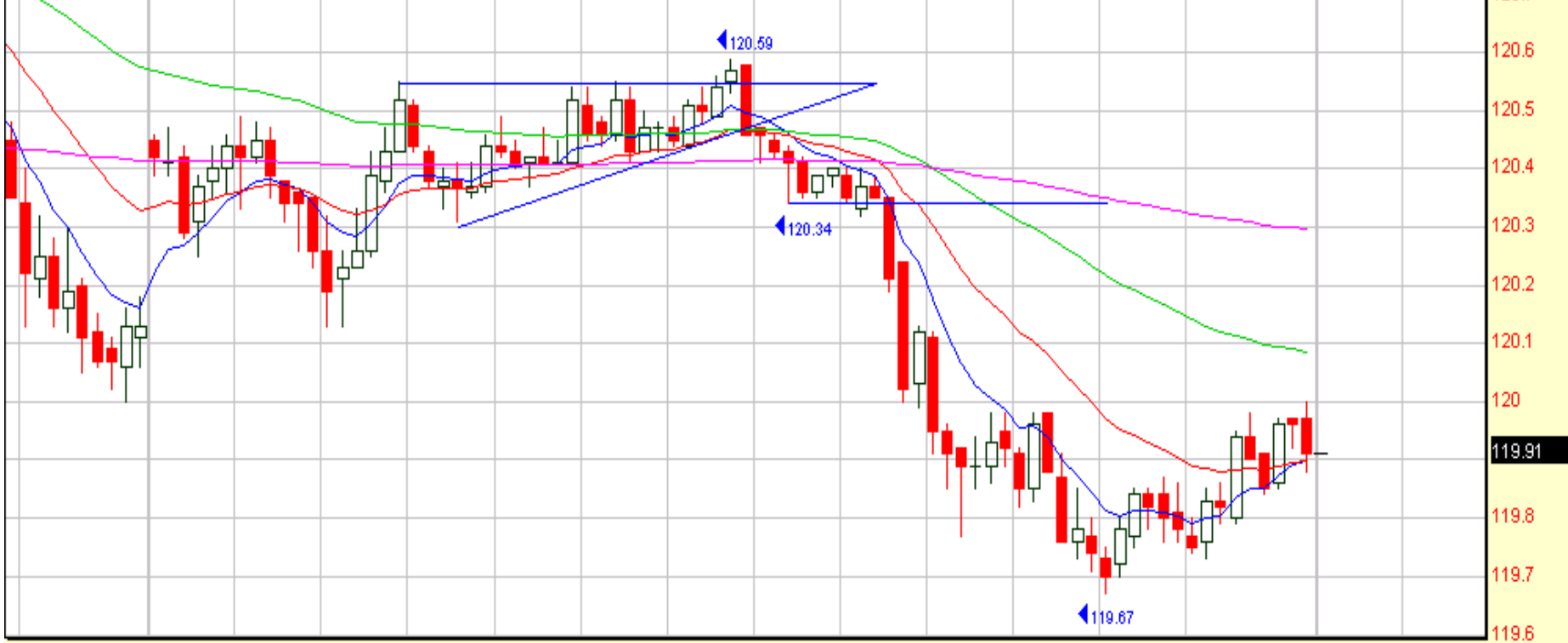

© 1998-2004 Prophet Financial Systems, Inc. | Terms of use apply.

Volume (Millions)

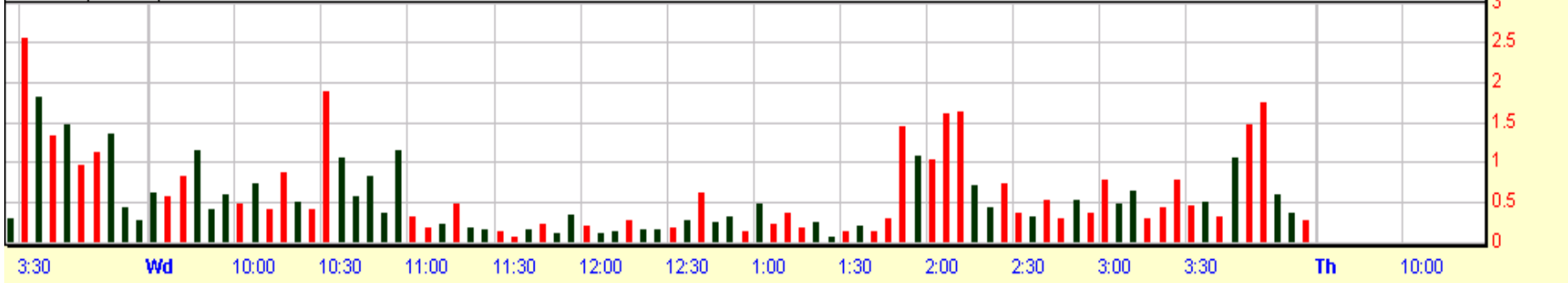

Exp. Mov. Avg. (8) Last=62.28  
Exp. Mov. Avg. (20) Last=62.16  
Exp. Mov. Avg. (60) Last=62.04  
Exp. Mov. Avg. (240) Last=61.47

← APA 5 MIN 6/9/05

← "ABOVE THE LINE STOCK"

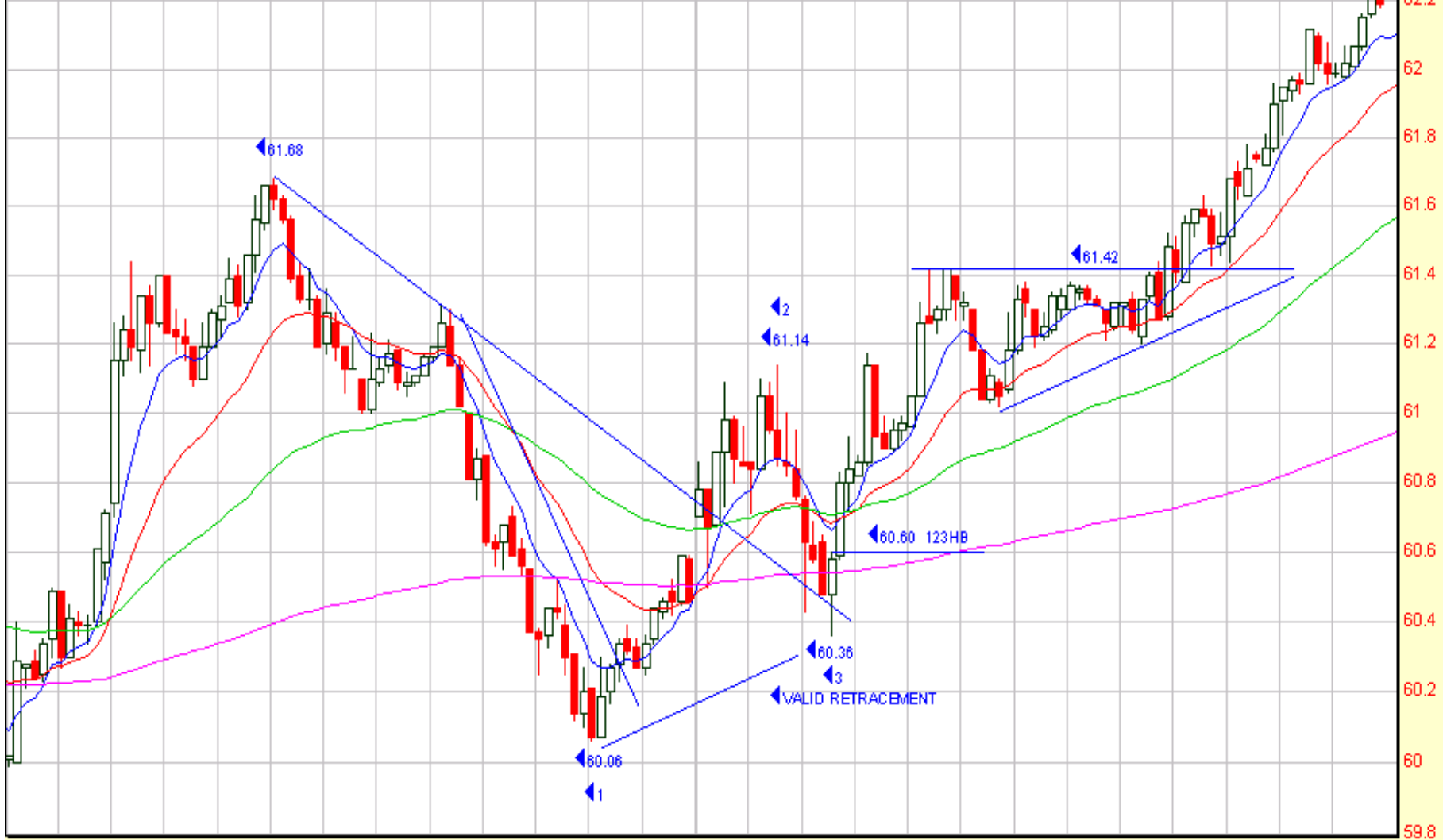

Wd 10:00 10:30 11:00 11:30 12:00 12:30 1:00 1:30 2:00 2:30 3:00 3:30 Th 10:00 10:30 11:00 11:30 12:00 12:30 1:00 1:30 2:00 2:30 3:00 3:30

NABORS INDUSTRIES LTD 59.50 0.30 0.51%

Exp. Mov. Avg. (8) Last=59.43  
Exp. Mov. Avg. (20) Last=59.33  
Exp. Mov. Avg. (60) Last=59.25  
Exp. Mov. Avg. (240) Last=58.40

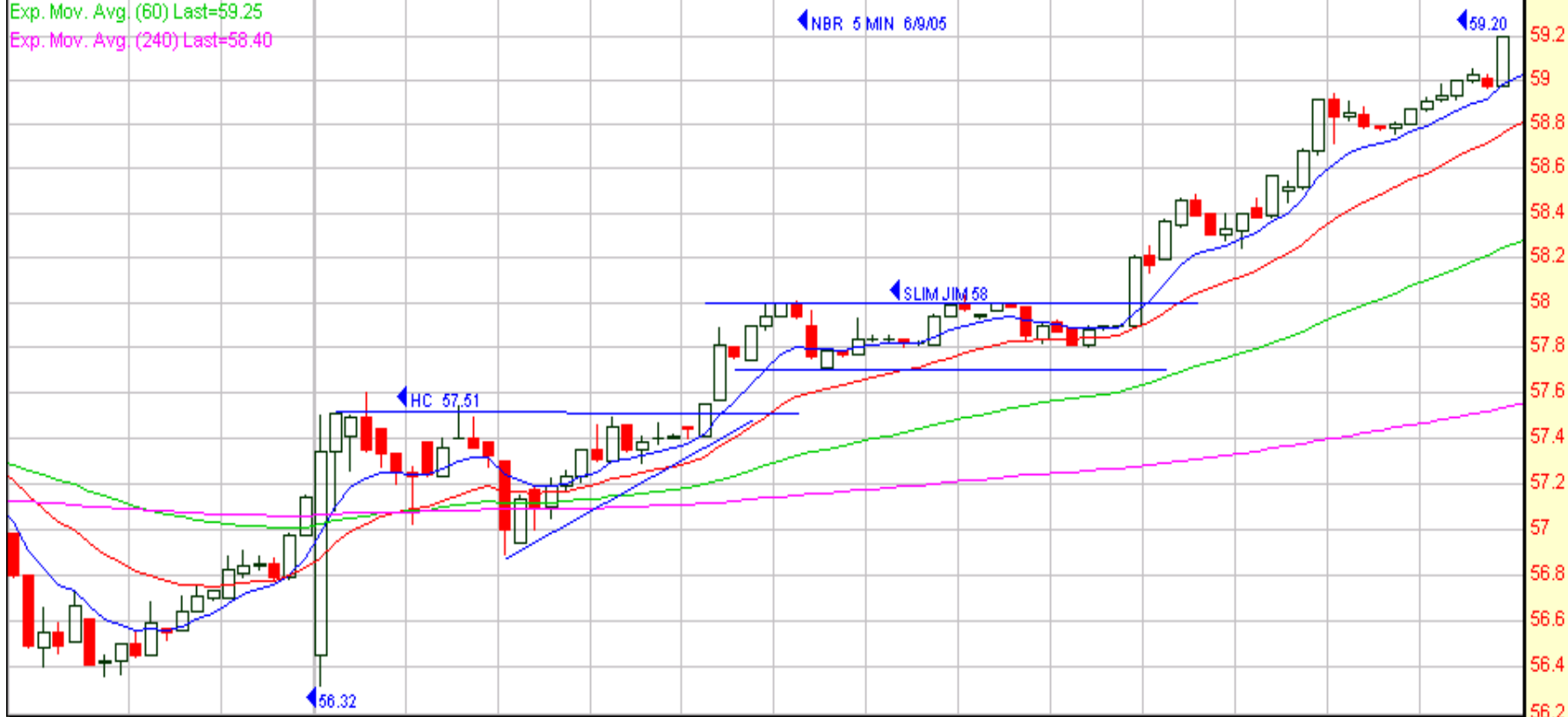

© 1998-2004 Prophet Financial Systems, Inc. | Terms of use apply.

Stochastic, Full (8,3,3)

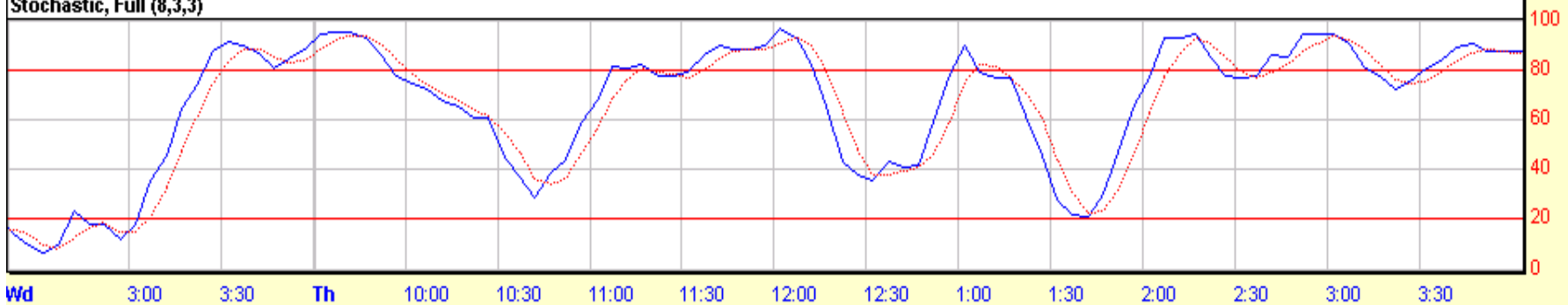

Wd 3:00 3:30 Th 10:00 10:30 11:00 11:30 12:00 12:30 1:00 1:30 2:00 2:30 3:00 3:30

EXELON CORPORATION 49.00 0.81 1.68%

Exp. Mov. Avg. (8) Last=49.08  
Exp. Mov. Avg. (20) Last=49.07  
Exp. Mov. Avg. (60) Last=48.88  
Exp. Mov. Avg. (240) Last=48.58



© 1998-2004 Prophet Financial Systems, Inc. | Terms of use apply.

Volume (Thousands)

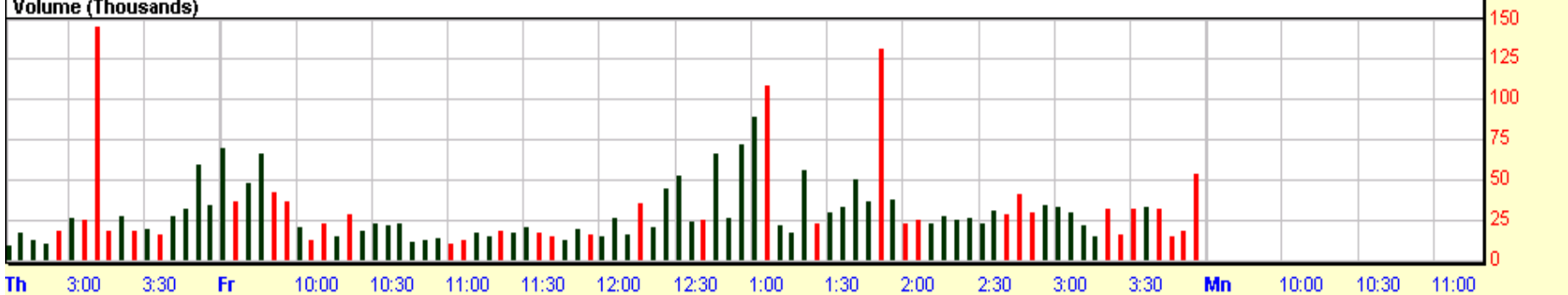

NEWMONT MINING CORP 38.67 0.60 1.58%

Exp. Mov. Avg. (10) Last=37.52  
Exp. Mov. Avg. (20) Last=37.42  
Exp. Mov. Avg. (50) Last=38.53  
Exp. Mov. Avg. (200) Last=41.30



© 1998-2004 Prophet Financial Systems, Inc. | Terms of use apply.

Volume (Millions)

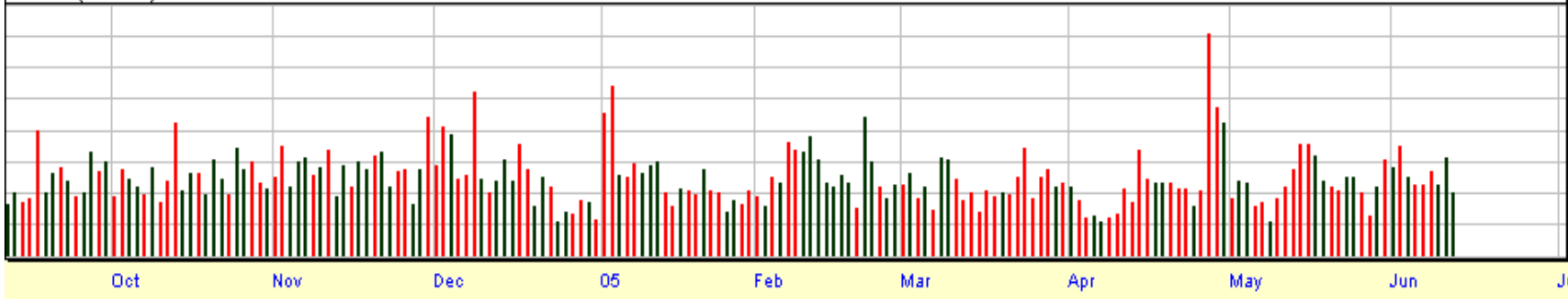

NEWMONT MINING CORP 38.63 0.56 1.47%

Exp. Mov. Avg. (8) Last=38.63  
Exp. Mov. Avg. (20) Last=38.61  
Exp. Mov. Avg. (60) Last=38.34  
Exp. Mov. Avg. (240) Last=37.65

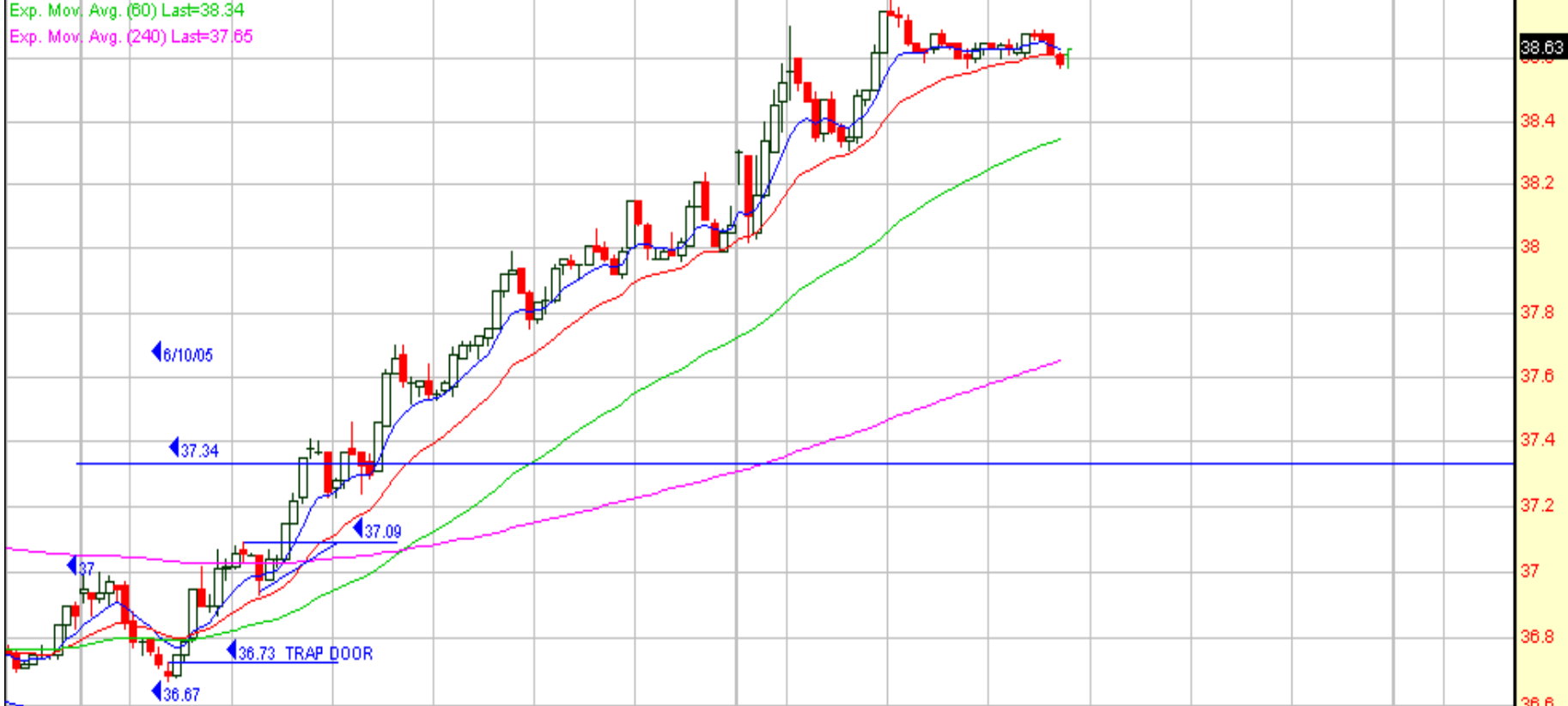

© 1998-2004 Prophet Financial Systems, Inc. | Terms of use apply.

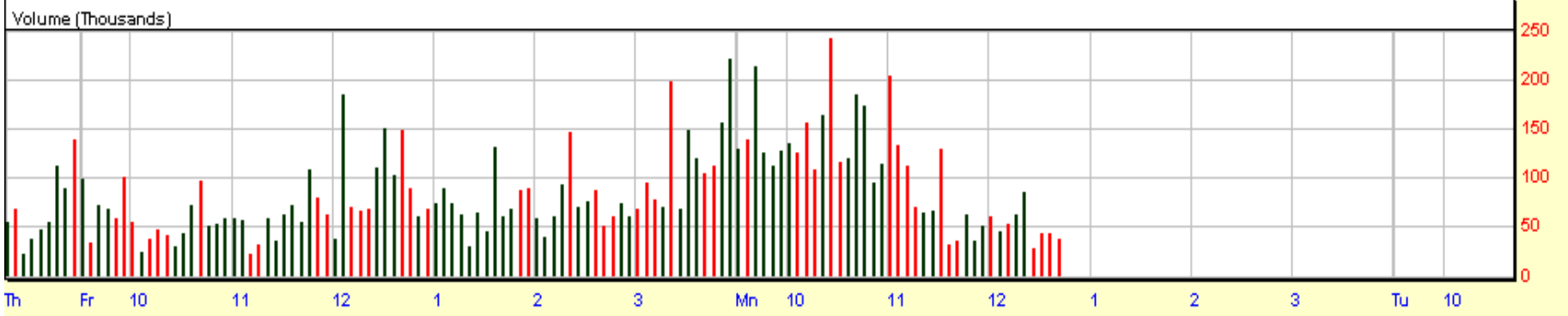

Exp. Mov. Avg. (8) Last=38.24

Exp. Mov. Avg. (20) Last=37.75

Exp. Mov. Avg. (34) Last=37.59

◀ NEM 60 MIN 6/13/05



© 1998-2004 Prophet Financial Systems, Inc. | Terms of use apply.

Volume (Millions)

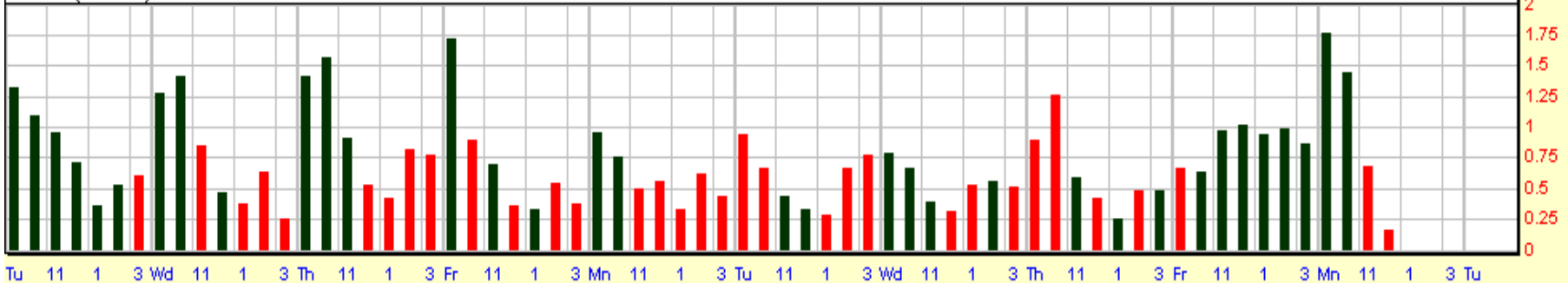

ISHARES TR LEHMAN 20+ YR 94.30 -0.59 -0.62%

Exp. Mov. Avg. (10) Last=95.13  
Exp. Mov. Avg. (20) Last=94.54  
Exp. Mov. Avg. (50) Last=93.00  
Exp. Mov. Avg. (89) Last=91.86  
Exp. Mov. Avg. (200) Last=89.67

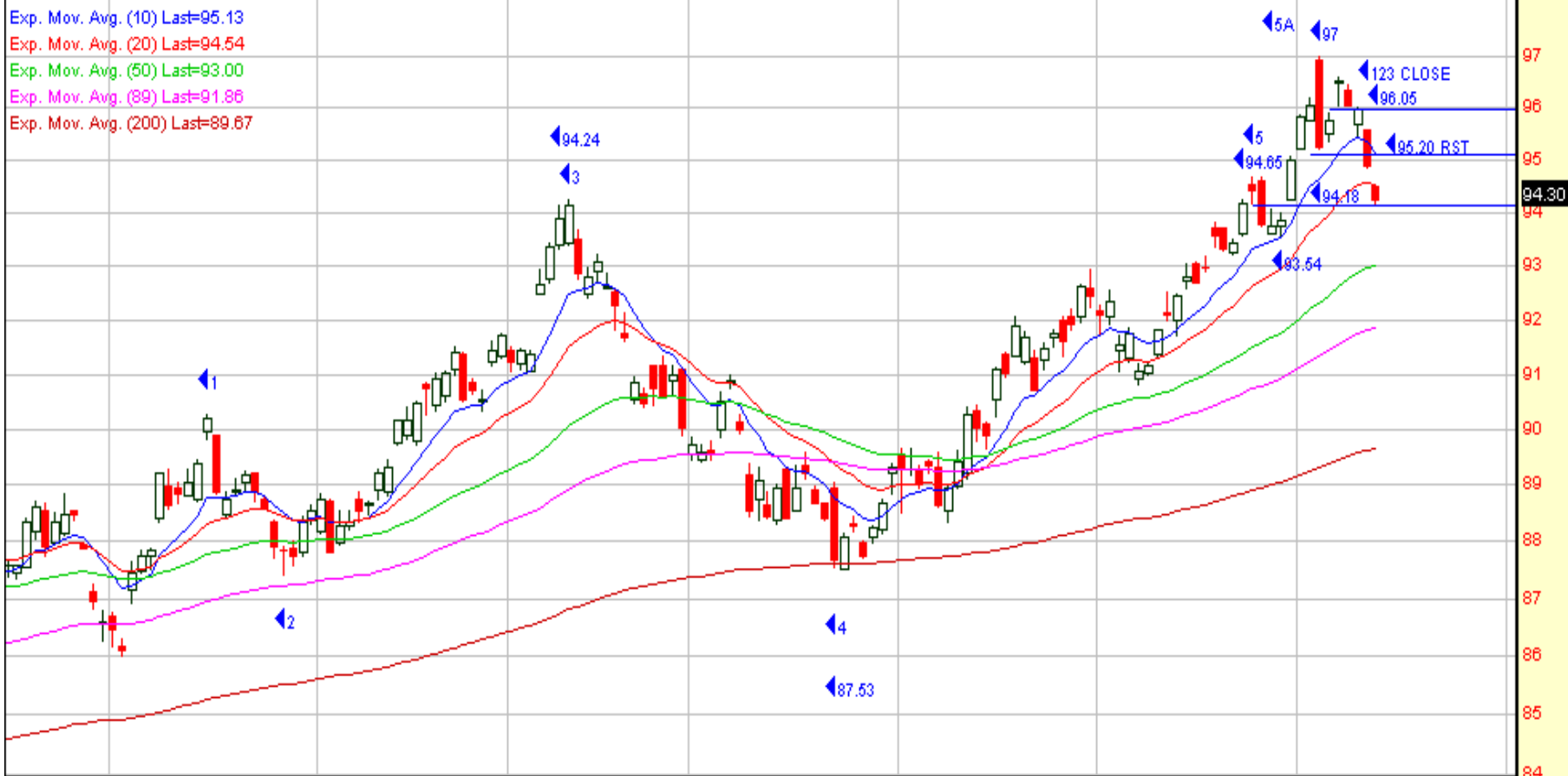

© 1998-2004 Prophet Financial Systems, Inc. | Terms of use apply.

RSI, Wilder (5)

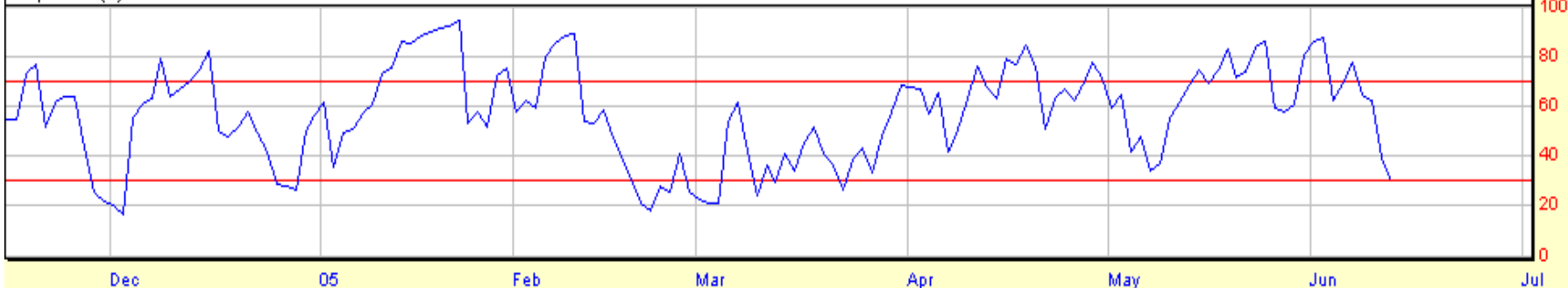



S&p 500 Index 1202.32 4.21 0.35%

Exp. Mov. Avg. (8) Last=1202.04  
Exp. Mov. Avg. (20) Last=1202.33  
Exp. Mov. Avg. (60) Last=1201.82  
Exp. Mov. Avg. (240) Last=1199.50

◀\$SPX 5 MIN 6/13/05



Th 3 Fr 10 11 12 1 2 3 Mn 10 11 12 1 2 3 Tu 10 11 12

NASDAQ 100 TR SERIES I(OTC) 37.73 0.183 0.49%

Exp. Mov. Avg. (20) Last=37.73  
Exp. Mov. Avg. (8) Last=37.72  
Exp. Mov. Avg. (50) Last=37.74  
Exp. Mov. Avg. (240) Last=37.74



© 1998-2004 Prophet Financial Systems, Inc. | Terms of use apply.

RSI, Wilder (5)



Exp. Mov. Avg. (8) Last=120.49  
Exp. Mov. Avg. (20) Last=120.49  
Exp. Mov. Avg. (60) Last=120.52  
Exp. Mov. Avg. (240) Last=120.34

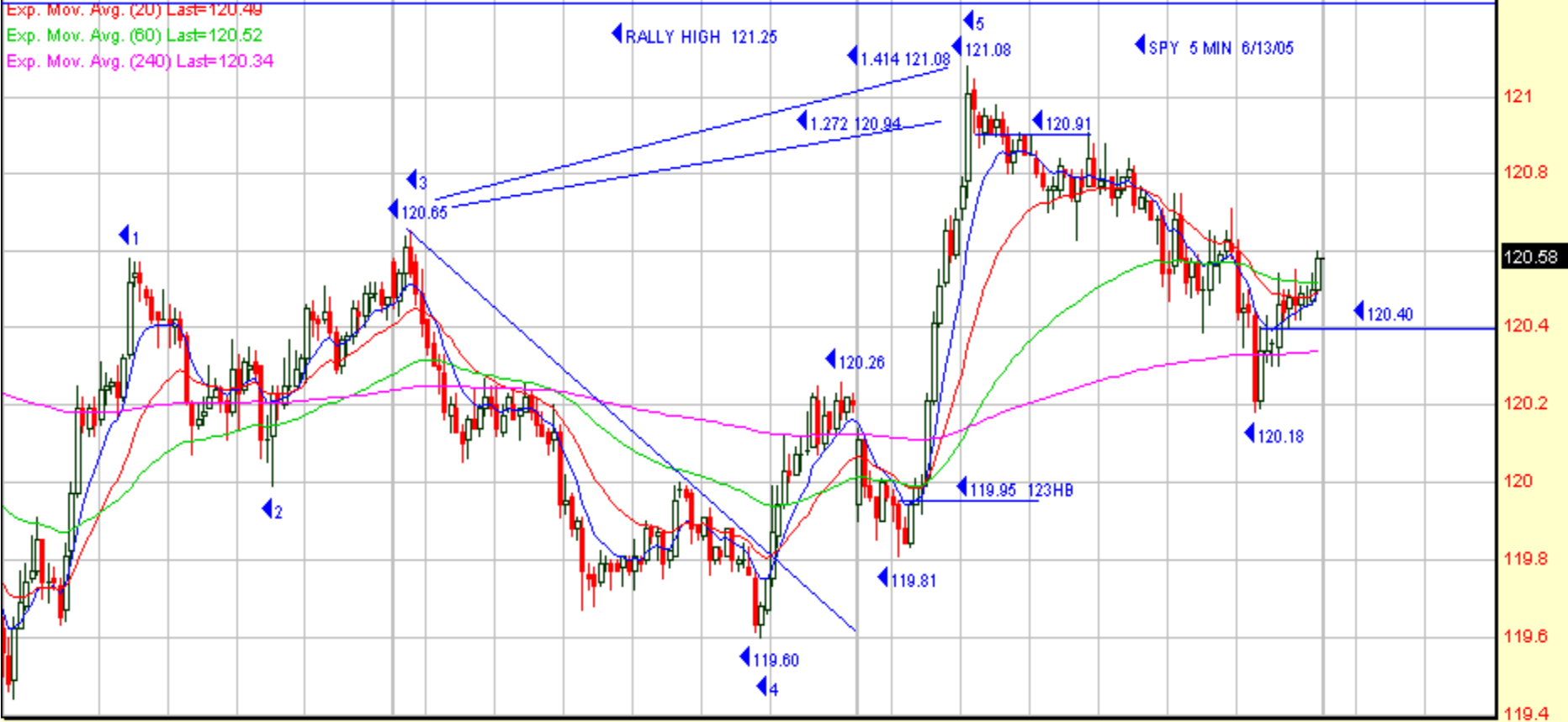

Stochastic, Full (8,3,3)

